



## MANUAL

**Creative Electronics and Software Inc.  
650 Sundown Road  
South Elgin, Il. 60177  
Tel: (847) 695-0023 Fax: (847) 695-0483**

*Innovative Technology*



*Superior Quality*

## BASE GAMES

***Global Domination:*** Players push large colored planets into a grid play-area in an attempt to connect four of the same colored globes in either an horizontal, vertical or diagonal line. The planets can be pushed in two dimensions, from both the top and bottom and left and right.

***Big Bang Bowling:*** A simulation of the classic sport, this game is sure to be a favorite with your patrons.

***Astro Hockey:*** This game is a simulation of air-hockey, allowing players to either play against each other, or try their luck against the computer.

***3D Tic Tac Toe:*** A twist on the normal version of the game, players must connect four spheres in three-dimensional space. The game can be played in two-player mode or against the computer player.

***Battle Bricks:*** Players must use their ball to break their way through a barrier of bricks and hit the precious "HeartBrick". Of course, their opponent will be trying to do the exact same thing, and will have many tricks to try and stop them.

***Flash Bowling 2000:*** A variant of bowling, players earn points based on strikes and spares.

***Galactic Golf:*** Nine holes of miniature golf, randomly chosen from the twelve holes provided. Players roll the trackball to aim, then press a button and roll the trackball for speed.

## CARTRIDGE GAMES

Along with the seven base games, your cocktail unit may support up to four expansion cartridges. All aspects of installing these games are done automatically by your unit, you only have to insert the cartridge onto the board and your games are ready to play! See the following page for a diagram of cartridge installation.

To install a cartridge, follow these step by step instructions:

1. **TURN OFF THE POWER. IT IS ESSENTIAL THAT THE POWER TO YOUR UNIT BE OFF WHEN ADDING OR REMOVING CARTRIDGES FROM THE MOTHERBOARD. FAILURE TO DO SO COULD CAUSE DAMAGE TO EITHER THE BOARD OR THE CARTRIDGE.**
2. Once the power is off, open the service access door (on the opposite side of the coin box door). *Note: Opening this door will automatically disconnect power, but we still recommend that you manually disconnect power yourself.*
3. Lower the door to its fullest extension. On the motherboard there are four slots. Pick any empty slot and press the cartridge gently but firmly into the slot. The cartridge is fitted such that it can only be inserted one way, so don't worry about inserting it incorrectly.
4. Once the cartridge is in place, close the service door and reconnect power. That's all there is to it! Audits, menus and high score changes will be handled automatically by your unit.

## HOW TO INSERT CARTRIDGE

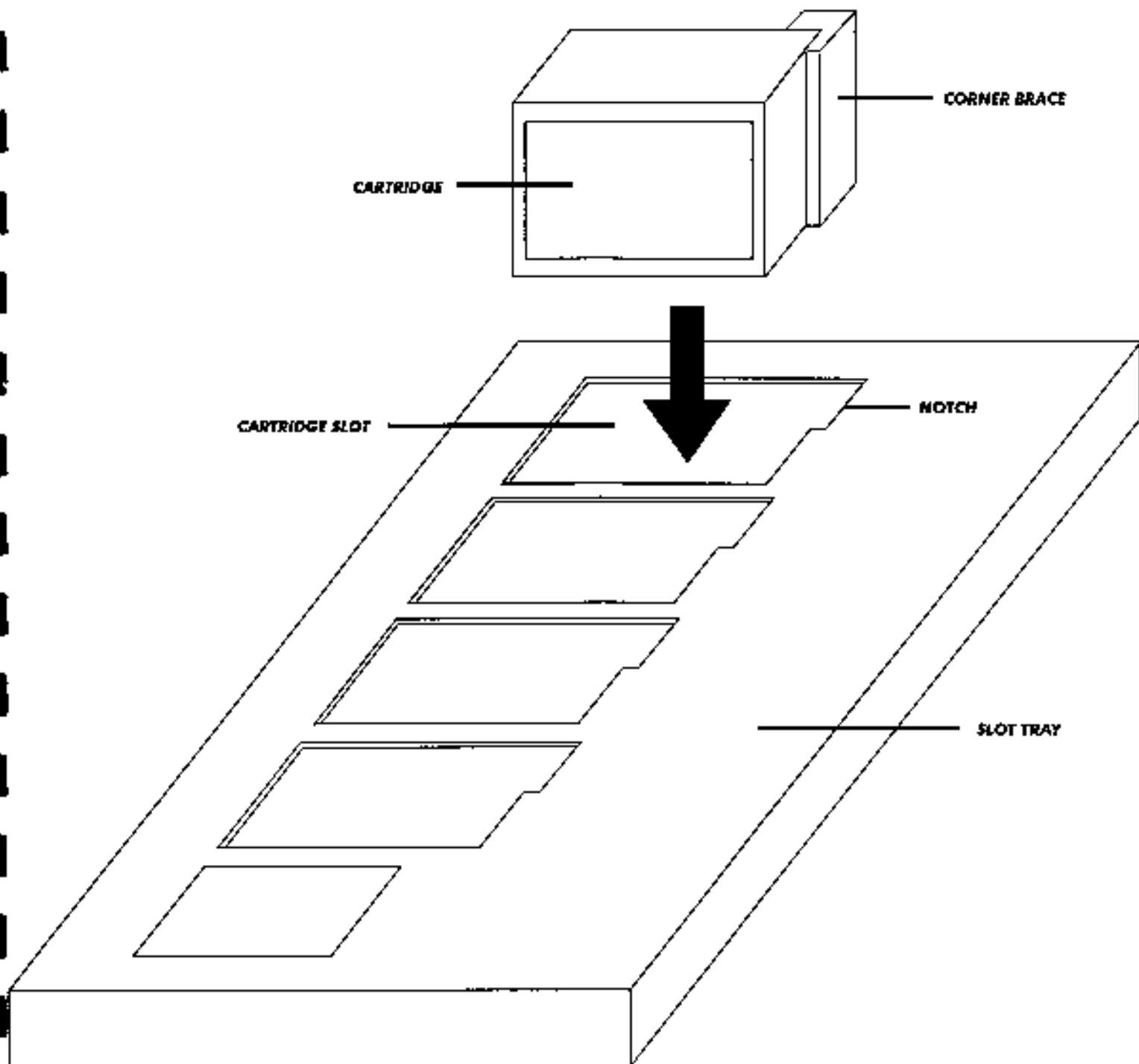

### **POWER MUST BE TURNED OFF BEFORE INSERTING ANY CARTRIDGE!!**

1. Open back door of Galaxy Games unit revealing the metal slot tray.
2. Line up corner brace on the cartridge with notch in cartridge slot (cartridge will not fit into slot unless corner brace and notch are lined up).
3. Insert cartridge into any slot and push down firmly on cartridge.
4. Close back door and power up the Galaxy Games unit. Software will automatically install new cartridge games.

## PEDESTAL INSTALLATION

The pedestal that is included with the game gives you the option of increasing the height of the game by approximately a foot and a half to accommodate standard height bar stools. This will allow your game to fit in with the rest of the tables in your location.

See the following page for a diagram of pedestal installation.

## DOLLAR BILL ACCEPTORS

Your Galaxy Games machine is wired to accept a CASHCODE dollar bill acceptor. There is a cable installed with the machine to accommodate a MARS dollar bill validator as well.

## HOW TO MOUNT GALAXY GAMES ONTO PEDESTAL

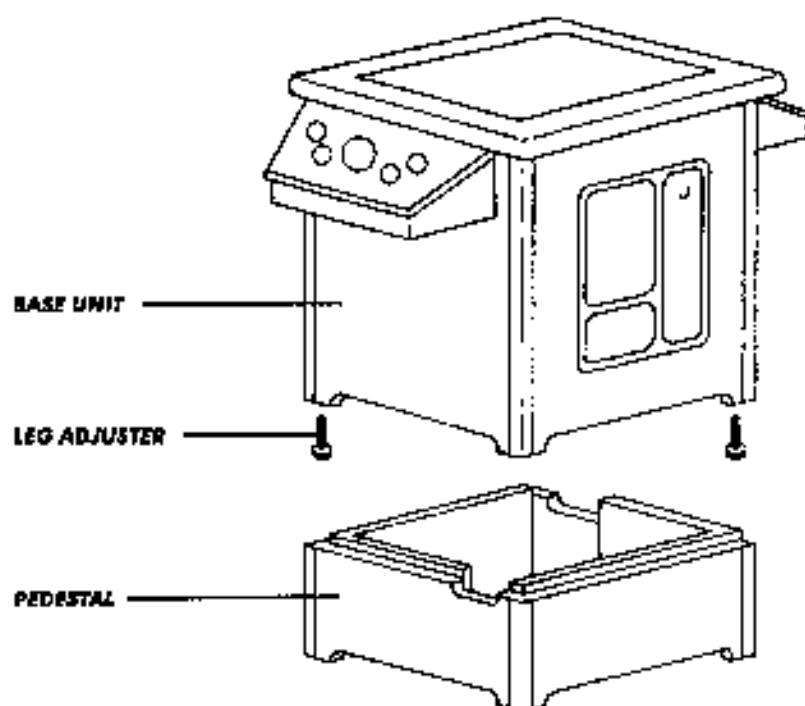

1. Remove Leg Adjusters from Galaxy Games base unit.

**NOTE: BASE UNIT WILL NOT FIT ONTO PEDESTAL  
UNLESS LEG ADJUSTERS ARE REMOVED**

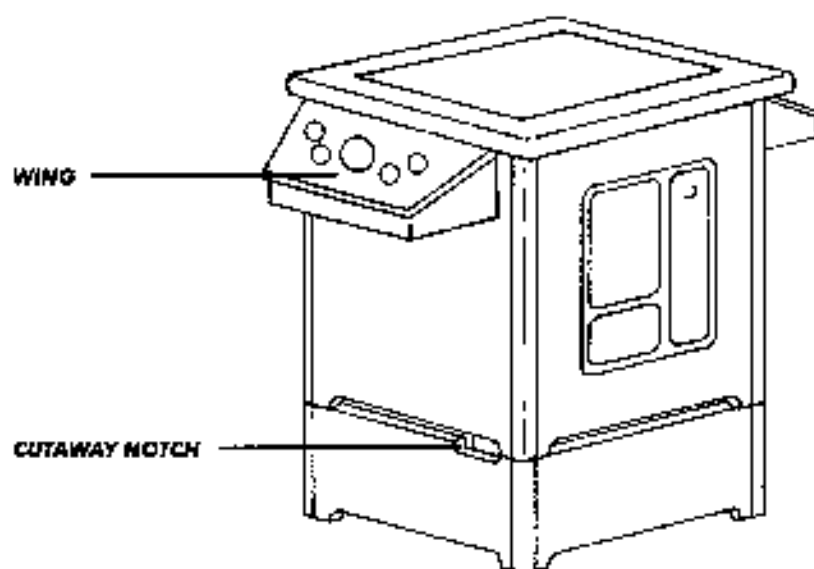

1. Place base unit onto pedestal. The pedestal has two cutaway notches on opposite sides. When placing base unit onto pedestal, these notches should be under (on same side as) wings of the base unit.

**NOTE: BASE UNIT WILL NOT FIT ONTO PEDESTAL  
UNLESS NOTCHES ARE UNDER WINGS**

## DIAGNOSTICS

You will find that *Galaxy Games* comes with a detailed and easy to use auditing system that grants a tremendous degree of control over your game and detailed descriptions of your cash flow. To access the diagnostic menu, open the coin-box door. Allow several seconds for the game to switch over into auditing mode. To leave diagnostics, close the coin door.

Once in the audit mode, you will see a screen displaying a tan colored worksheet with a blue background. Towards the top of the screen you will see several options, indicated as folder tabs. These tabs should be labeled as follows: **Main, Audits, Tests, Games, and High Scores.**

## Audits: Main Menu

**Credit Box:** Toward the lower left portion of the main audit menu will be a box labeled "Credits". Inside the box, you will see another heading of "Credits" in black lettering. This area shows how many credits are currently available. Players may obtain more credits by inserting money.

**Award Free Credit:** Each time this box is pressed, you will make one more credit available to the player. This operator can use this option to refund a credit or to test the system.

**Max Credit:** Sets the limit of how many credits may be available at once. The default value is 30. If players enter more money after this limit has been reached, the unit will NOT grant additional credits.

**Advertising Screen:** You may use this option for creating custom advertising screens. This advertising screen is one of the attract modes used by the game and can display a particular message for your environment. To create your message, press this box. You will then be taken to an editing screen that will allow you to enter your message. You have eight lines of text for your message. Use your pointer to select the letters. The "TXT COLOR" option will cycle through different colors for your message. PREVIEW allows you to view what the message will look like. CLEAR will erase all text lines. Use the BACKSPACE option to erase mistakes on the current text line. RETURN allows you to cycle through the different text lines. Press DONE once you are satisfied with the message. Messages are centered automatically.

**Ad Freq:** Clicking this button changes how often the advertising screen comes up in attract mode.

**Language:** This option will allow the game to be played in different languages. Press the button to cycle to the language you wish to use.

**Restore Factory Settings:** This option will reset ALL options to the default values assigned at the factory. Use the option ONLY when you wish to reset everything back to its default value.

**Free Play:** This option toggles the free play mode on and off.

**Volume Slider:** Use this slider to determine how loud the sounds will be on the game. Press the up arrow at the top of the slider to increase volume, the down arrow to decrease volume.

## Audits Menu

**Main Audits:** This menu will tell you most of the information you need to keep tabs on your cash flow. Here is a brief list of these items and what they mean:

**Coins In:** Shows how many coins were actually physically put into the game.

**Paid Credits:** Shows how many credits were awarded by someone paying for them.

**Operator Credits:** Shows how many credits were awarded by granting a free credit (see the *Award Free Credit* option in the previous section).

**Freeplay Credits:** Shows how many credits were played while in freeplay mode.

**One Player Games:** How many of the games played were in a one-player mode.

**Two Player Games:** How many of the games played were in a two-player mode.

**Average Game Time:** What the average length of time a game played on your machine was.

### Game Audits:

Each of the individual games has its own unique auditing system. This way, you can tell which games are more successful for your particular patrons. To access the game audits, select the large black right arrow at the bottom of the Audits Menu. You will then cycle through an auditing screen for each individual game on your unit (cartridge games will also be shown).

## Tests Menu

The next section of the audits will give audio, video and mechanical diagnostics of your machine.

### Video

This section of the test menu will determine if your monitor settings are satisfactory.

**Alignment** – Displays a grid for vertical and horizontal adjustments.

**Red Screen** – Displays a screen of all red to determine red adjustment.

**Blue Screen** – Displays a screen of all blue to determine blue adjustment.

**Green Screen** – Displays a screen of all green to determine green adjustment.

**Gradient** – Displays a gradient of colored boxes, used to determine proper monitor adjustment.

### Sound

This segment will allow you to test your machine's internal speakers.

**Stop** – Stops the current sound being played.

**Play** – Plays the current sound.

**Next** – Selects the next sound in memory for test.

### Mechanical

This area of the test menu will perform switch tests on the machine. Specifically, the status of the various switches are displayed. Pressing one of the buttons will cause the status of the switch to change from OPEN to CLOSED. This will help you troubleshoot any problems you may be having with your switches.

## Games Menu

From these audit menus, you will be able to custom set the amount of money each of your games requires to play. The first of these menus is the coin setup menu.

### Coin Setup

In this menu, you will see a 3x3 matrix. Along the rows are three headings, Coin Switch 1, Coin Switch 2 and DBA. Along the columns are the headings Coins, Credits and Meter Clicks.

Coin Switch 1 and 2 represent the first and second coin slots respectively, and DBA stands for Dollar Bill Acceptor. For your revenue setup, you will want to focus your attention to the rows of this matrix.

If you look across the first row (Coin Switch 1), you will notice the numbers 1 1 1. This means that each coin will give the player one credit and click the meter counter once.

Example: If you wanted to install a nickel coin mechanism on coin switch one, but wanted each game to cost a dime, you would change the number of coins to 2, the number of credits to 1, and the number of meter clicks to 1. That means for every two nickels deposited in the machine the player gets one credit, and the meter is clicked once for each coin inserted.

### Game Headings

By clicking the forward arrow in the bottom right corner of the Games menu, you can go into the menu screens for each individual game.

Pressing this arrow once takes you to the menu for *Global Domination*. You will notice there are three sections for this menu screen: *Game is On/Off*, *Credits Needed*, and *Number of Rounds*. It is these functions that allow you to control further aspects of revenue input and gameplay. Each game has a similar menu to *Global Domination* to determine the amount of credits needed and length of gameplay.

By changing a *Game is* to OFF, you can take a game off the main menu.

The *Credits Needed* function is another way to set how much money is needed to play the game. Setting this number to two will require the players to enter two credits in order to play the game.

The *Number of Rounds* option tells the machine how many rounds the game will last before ending. By setting this number, you can determine how much gameplay the user will have.

## High Scores Menu

This section of the audits will give you control over the high scores for your game. The first option you will see is *High Scores Reset After...* This option will determine when the high scores will automatically reset to factory settings. By adjusting the setting of this option, you can determine how frequently the high score tables can be refreshed, allowing your different players a chance to get the names into the table. The number determines after how many times the game is played this reset will occur.

By pressing the forward arrow at the bottom right of this screen, you may scroll through a menu screen for each individual game.

Under each game, you will see two options, *Clear* and *Reset All High Scores*. The *clear* option sets all the high scores for that game to zero, and erases all the names entered in that game.

The *Reset All High Scores* option will reset the high scores to factory settings **FOR ALL THE GAMES IN THE MACHINE**. Note that even though this option exists on each individual game screen, they will each perform the same function. Use this option only when you wish to reset all of your high scores.

A unique feature to your *Galaxy Games* machine is its ability to screen out foul language from the high score list. Players who attempt to enter one of the hundreds of inappropriate high score names will not be successful. The game will enter a blank high score name in place of the inappropriate phrase.

## MONITOR SERVICE

In order to service the monitor, follow these steps:

1. ***MAKE CERTAIN THE POWER IS OFF! MONITORS REQUIRE A SUBSTANTIAL AMOUNT OF POWER. EXPOSURE TO THIS COULD EITHER CAUSE SERIOUS INJURY OR DEATH.***
2. **You must raise both panels of the trackball controls in order to access the monitor. Lift up each panel, and use the swingarm to hold the panel in place.**
3. Swing the monitor upwards until it is perpendicular with the floor. On the inside of the cabinet, you will find a swingarm to hold the monitor in place. Once this swingarm is locked into place, you are ready to service the monitor.

*Note: Do NOT attempt to lift the monitor before raising the panels over the trackballs. Failure to do this may result in cracking of the monitor glass.*

*SEE THE FOLLOWING PAGE FOR A DIAGRAM OF MONITOR SERVICE.*

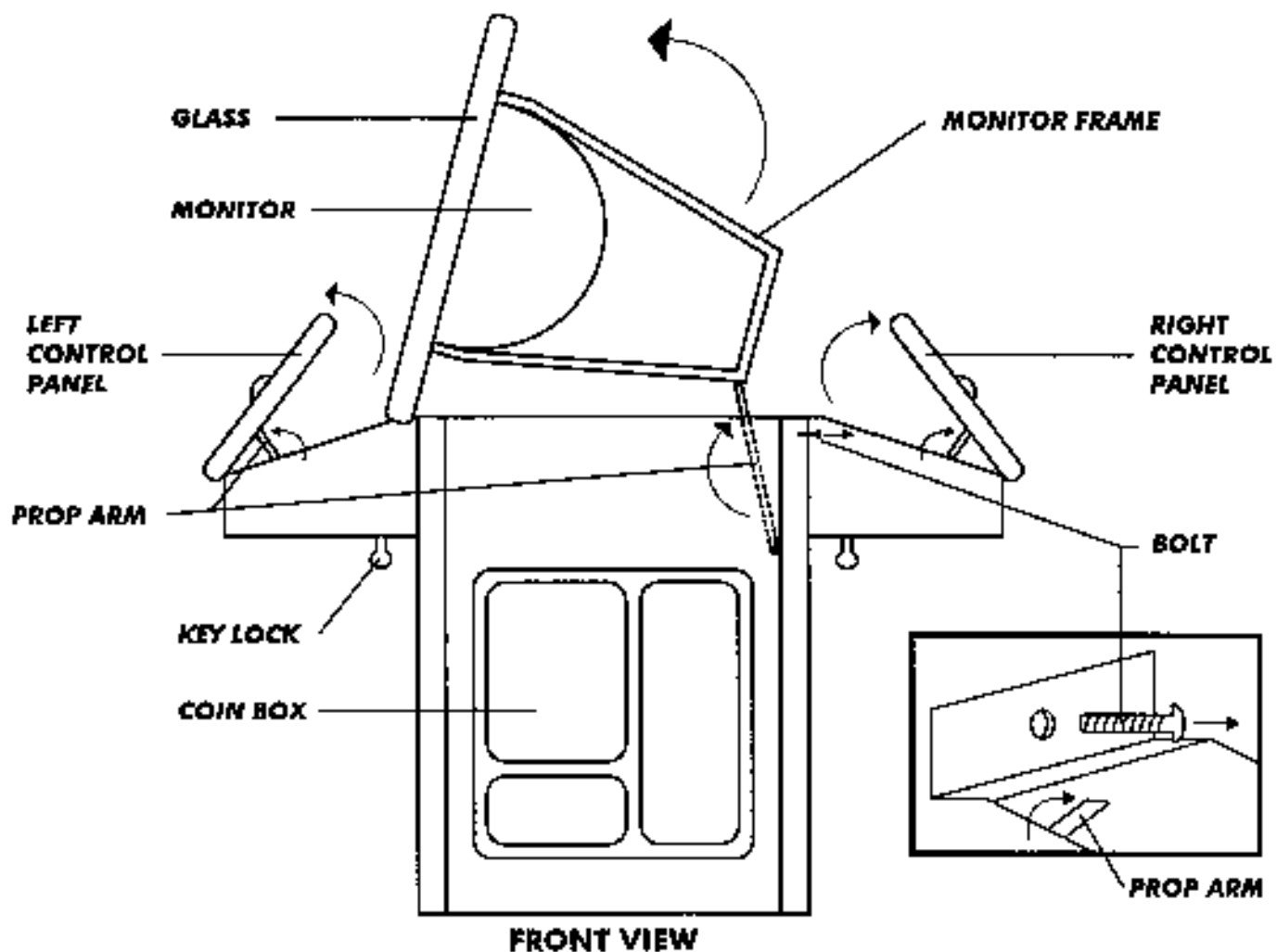

### HOW TO ACCESS GALAXY GAMES CABINET FOR SERVICE / CARTRIDGE INSTALLATION

1. **Unlock both left and right control panels using key locks located underneath each control panel housing.**
2. **Lift both left and right control panels and prop them up using prop arms located in each control panel housing.**
3. **Remove single bolt from inside right control panel housing. (see Insert diagram) This bolt unlocks the glass/monitor.**
4. **Lift glass/monitor and prop to monitor frame using prop arm located inside cabinet housing.**

**WARNING: BEFORE LIFTING MONITOR, LEFT CONTROL PANEL MUST BE PROPPED UP, OR ELSE MONITOR WILL NOT LIFT FULLY AND GLASS TOP MAY BE DAMAGED OR BROKEN!!**

## WARRANTY INFORMATION

Your *Galaxy Games* unit comes with a one year warranty. Should something go wrong with your unit, contact CES at (847) 741-9820 to talk to a customer service representative who will guide you through the repair process and provide warranty service as needed.

### NOTE:

**IN ORDER FOR YOUR WARRANTY TO BE VALID, THE MOTHERBOARD MUST NOT BE REMOVED FROM THE METAL BOX HOUSING. TO OBTAIN A NEW MOTHERBOARD, THE OLD UNIT MUST BE RETURNED IN ITS METAL BOX HOUSING. REMOVAL OF THE MOTHERBOARD FROM THE HOUSING WILL VOID YOUR WARRANTY!**

## REPLACEMENT PART NUMBERS

9FCRTMONT-0019	19" CGA Monitor
9FMETMT-0002	Control Panel Hinge
9FMETMT-0037	Cabinet Corner Trim
9FMETMT-0005	Glass Frame Bracket
9FMETMT-0011	DBV Plate
9FMETMT-0012	Control Panel Stay Arm
9FMETMT-0020	Speaker Grill
9FMETMT-0026	Monitor Stay Arm
9FCBCASHDK-0001	Coin Door
9FCBL-JAMA-0001	JAMMA Harness
9FCBLCB-0005	Coin Door Cable
9FCBLCB-0002	Power Cable
9FGLSGLASS-0001	Screened Glass
9FDCLCP-0001	Control Panel Decal
9FDCLDCAL-0001	Logo Decal
9FMANMAN-0001	Manual
9FPSPSUP-0001	Power Supply
9FSWTBPB-0001	Blue Switch
9FSWTBPB-0002	Red Switch
9FTRKTRACK-0001	Red Trackball
9FPWRTRACKLITE	Trackball Light

Player 2

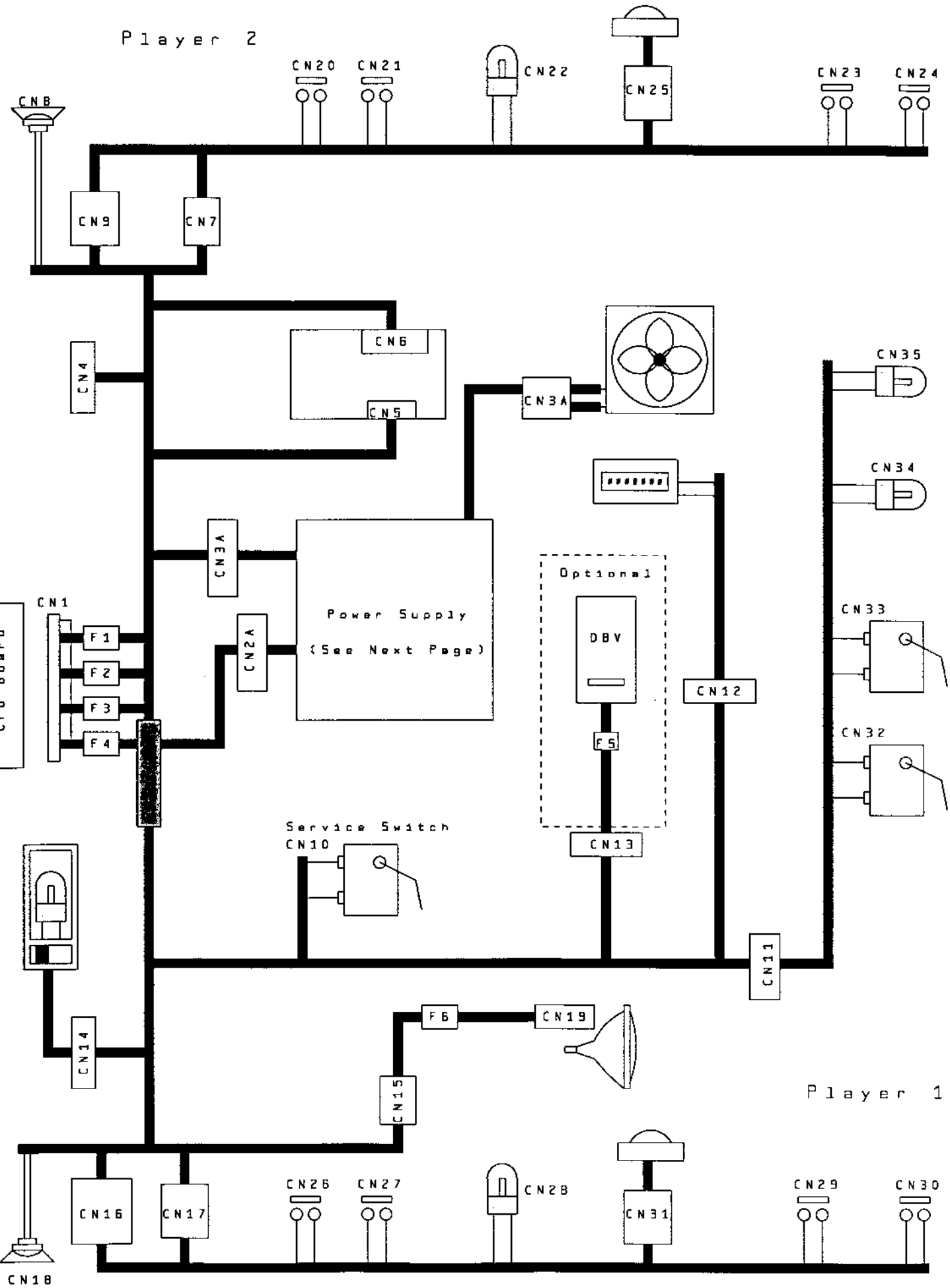

Player 1

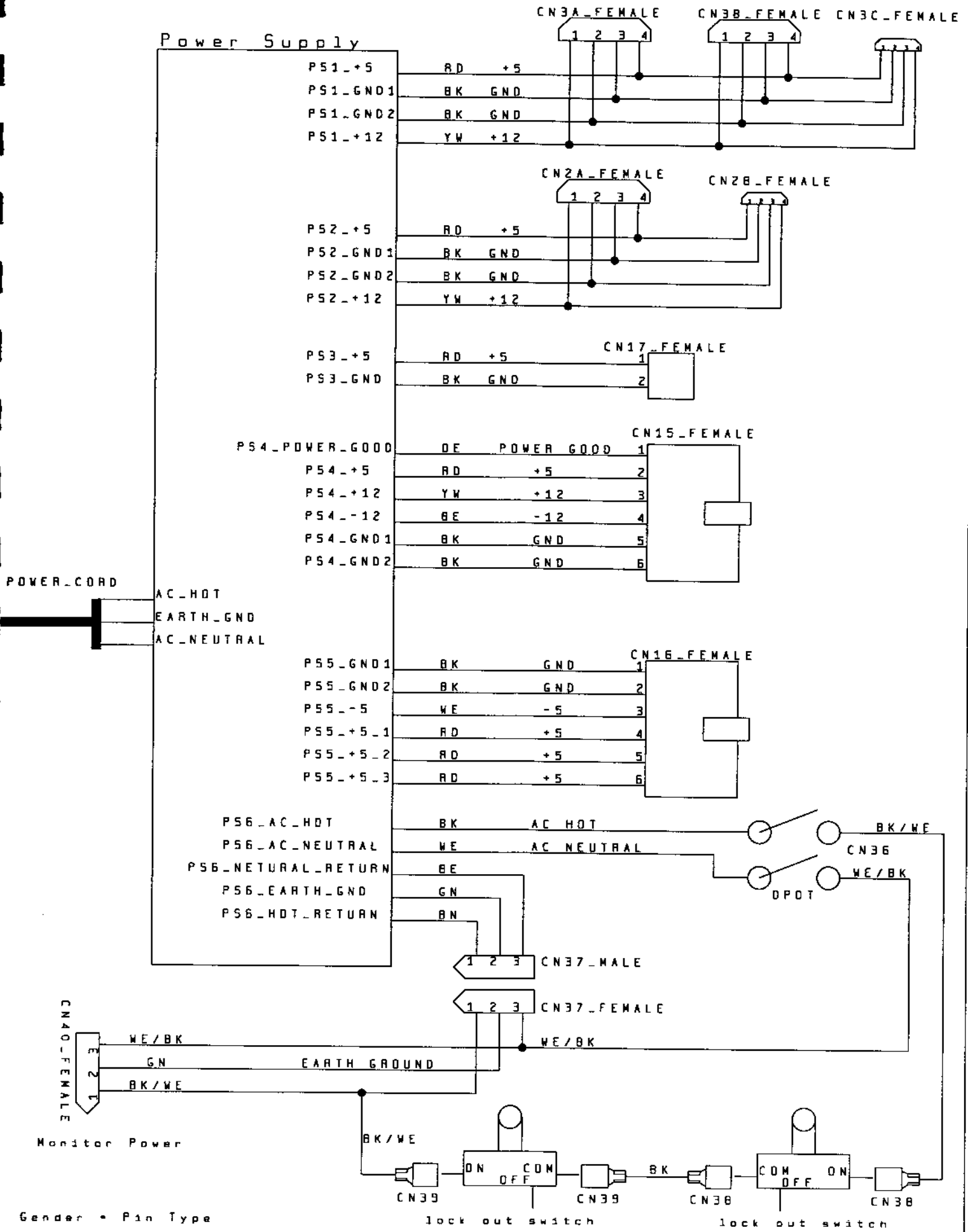

Gender • Pin Type

lock out switch

lock out switch

Component Side

Solder Side

GND	BK	1	101	BK	GND
GND	BK	2	102	BK	GND
+5	RD	3	103	RD	+5
+5	RD	4	104	RD	+5
		5	105		
+12	YW	6	106	YW	+12
TIP-122 COIN METER	BE/BN	8	108		
TIP-122 Trackball 1 Light	YW/BK	9	109	BN/GN	TIP-122 Trackball 2 Light
Audio Out +	WE/BK	10	110	BK/WE	Audio -
HORIZONTAL SYNC	WE/PE	11	111		
RED VIDEO GUN	RD	12	112	GN	GREEN VIDEO GUN
BLUE VIDEO GUN	BE	13	113	WE	VERTICAL SYNC
VIDEO SIGNAL GND	GN/BK	14	114	BN/WE	SERVICE SWITCH
		15	115	WE/BN	EXTRA SWITCH INPUT
COIN SWITCH 1	WE/YW	16	116	GN/YW	COIN SWITCH 2
		17	117		
TRACK BALL 1 - Y1	DE/BE	18	118	BN/BE	TRACK BALL 2 - Y1
TRACK BALL 1 - Y2	GN/DE	19	119	DE/WE	TRACK BALL 2 - Y2
TRACK BALL 1 - X1	GN/BE	20	120	DE/GN	TRACK BALL 2 - X1
TRACK BALL 1 - X2	RD/YW	21	121	WE/DE	TRACK BALL 2 - X2
PLAYER 1 PUSH BUTTON A	RD/WE	22	122	BN/BK	PLAYER 2 PUSH BUTTON A
PLAYER 1 PUSH BUTTON B	WE/RD	23	123	YW/WE	PLAYER 2 PUSH BUTTON B
		24	124	RD/BK	Dollar Bill Validator
		25	125		
		26	126		
GND	BK	27	127	BK	GND
GND	BK	28	128	BK	GND

CN1\_FEMALE Janna

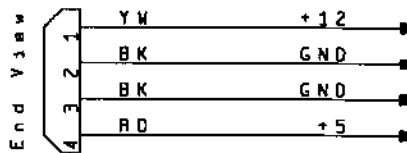

CN2A\_MALE Janna Power

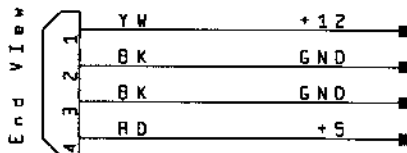

CN3A\_MALE Control Pannel Power & Coin Door

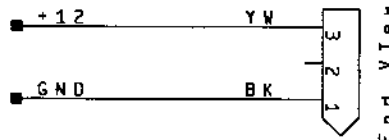

CN4\_MALE Reserved #1

Wire Insertion View

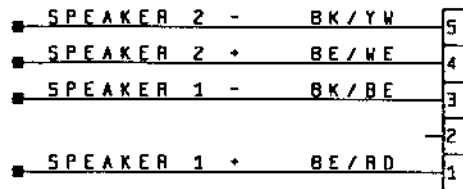

Wire Insertion View

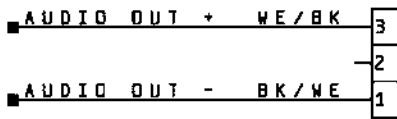

CN5\_FEMALE Sound Board In

CN6\_FEMALE Sound Board Out

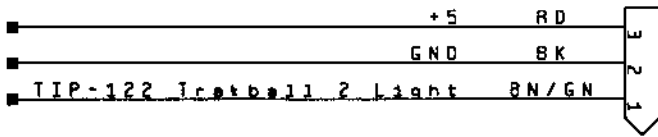

CN7\_MALE Power & Trackball Light

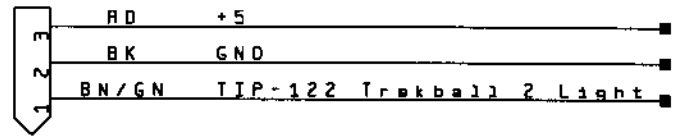

CN7\_FEMALE

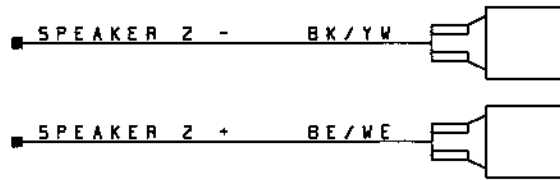

CN8\_FEMALE Speaker 2

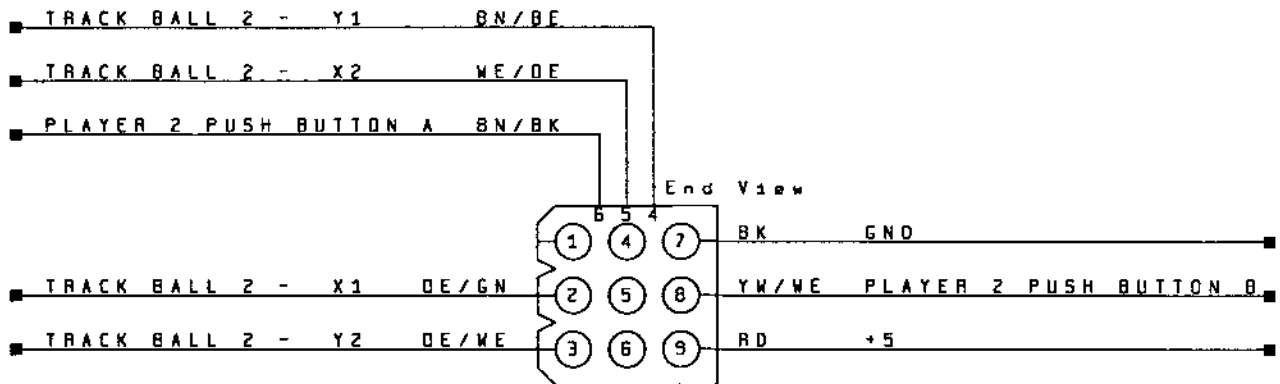

CN9\_MALE Control Panel Player 2

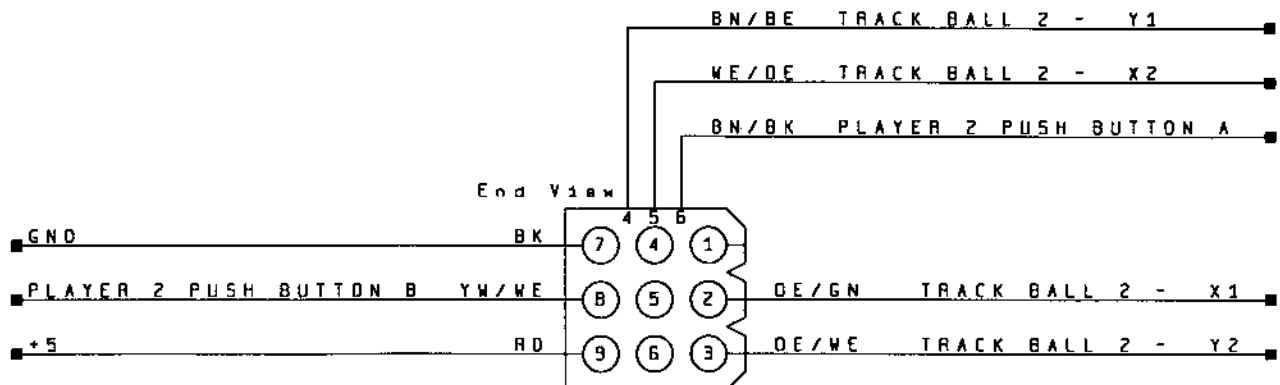

CN9\_FEMALE Control Panel Player 2

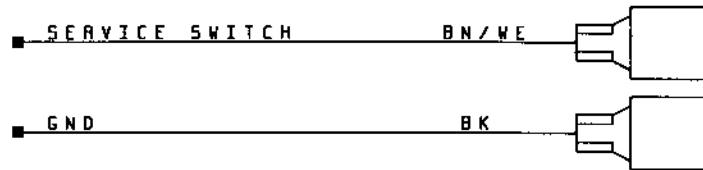

CN10\_FEMALE Service Switch

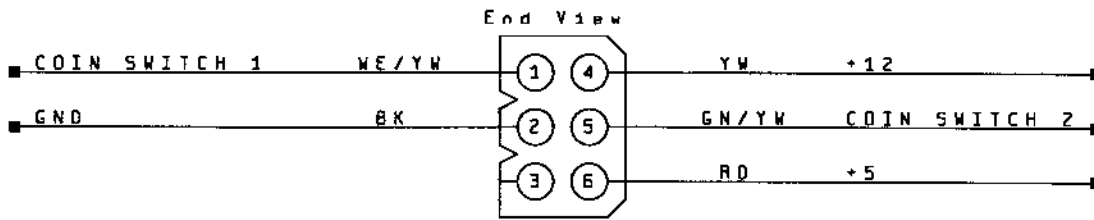

CN11\_MALE Coin Door

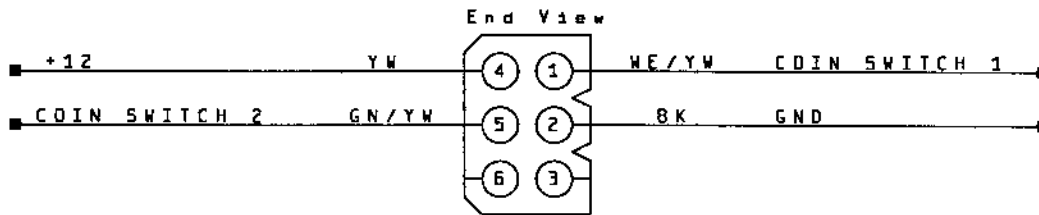

CN11\_FEMALE Coin Door



CN12\_MALE Coin Meter

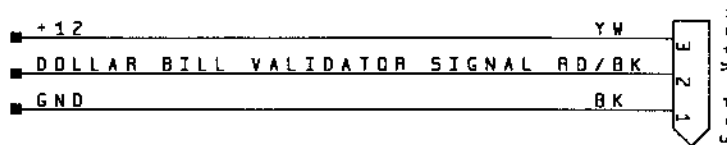

CN13\_MALE Dollar Bill Validator

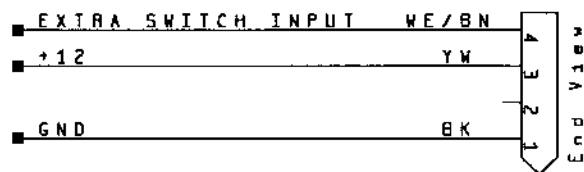

CN14\_MALE Service Light & Extra Switch input

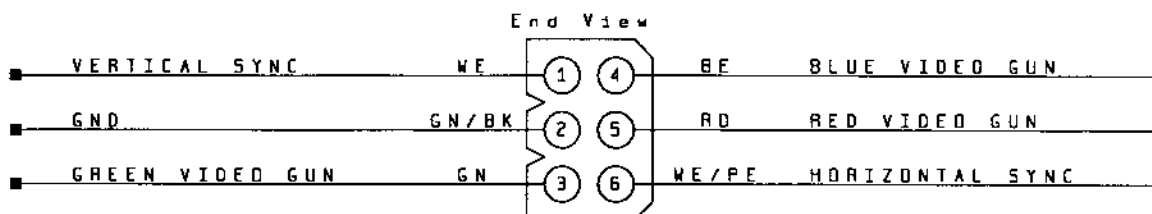

CN15\_MALE Video Connector

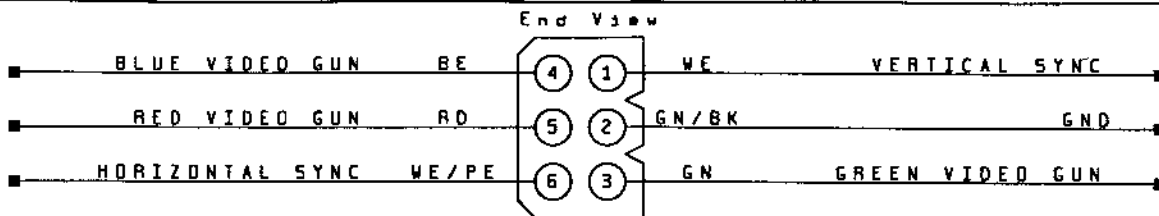

CN15\_FEMALE Video Connector

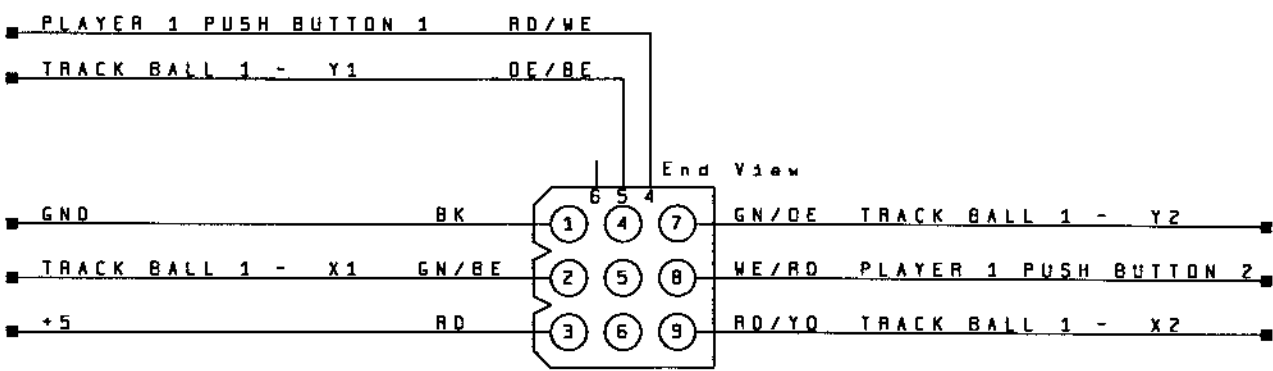

CN16\_MALE Control Panel Player 1

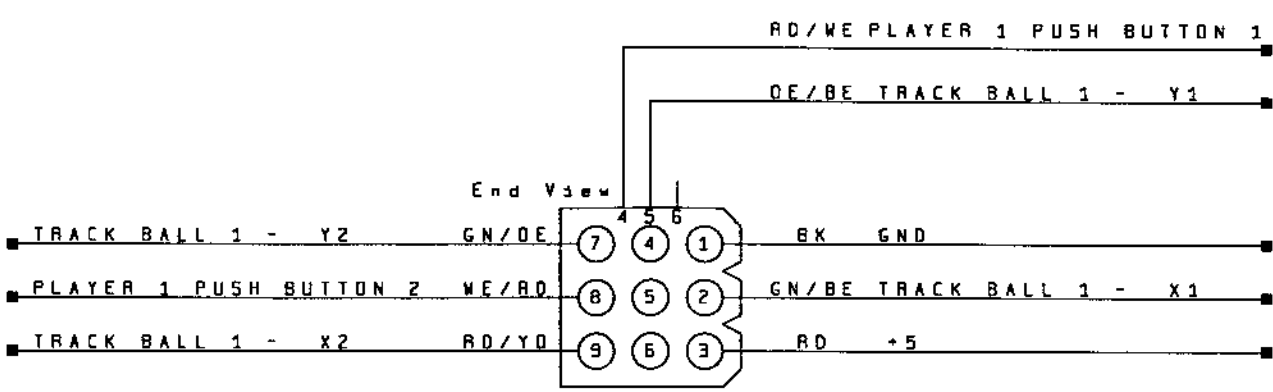

CN16\_FEMALE Control Panel Player 1

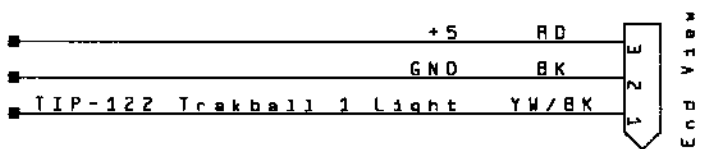

CN17\_MALE Power & Trackball light

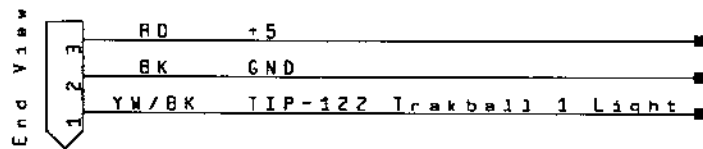

CN17\_FEMALE Power & Trackball light

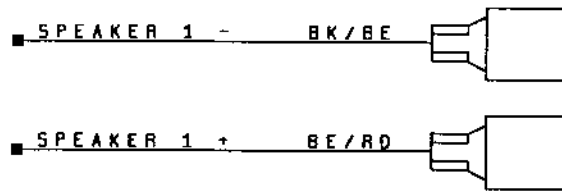

CN18\_FEMALE Push Button Connectors & Speaker

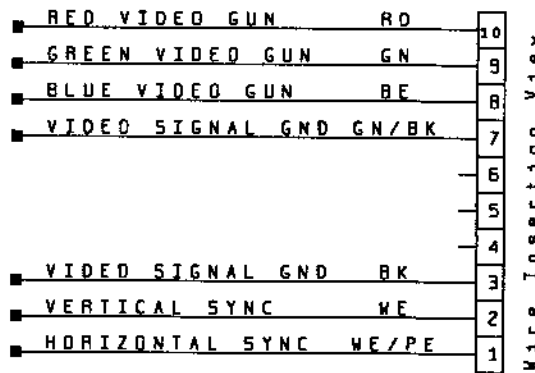

CN19\_FEMALE Video Monitor

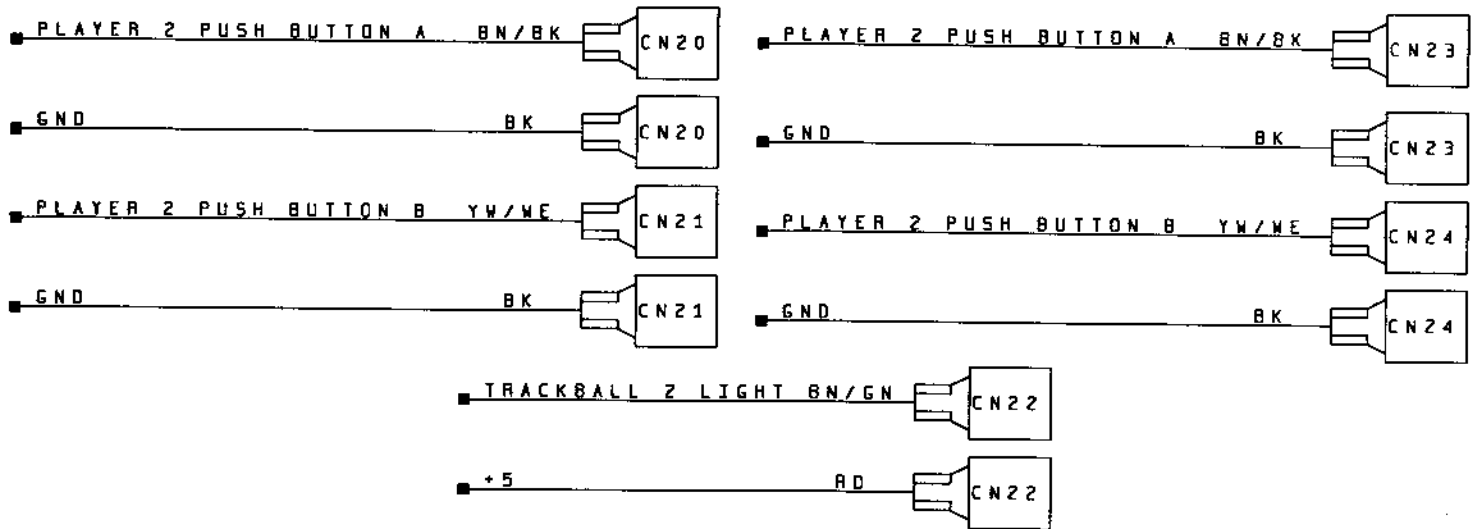

CN20-24 Player 2 Push Button Connectors & Trackball Light

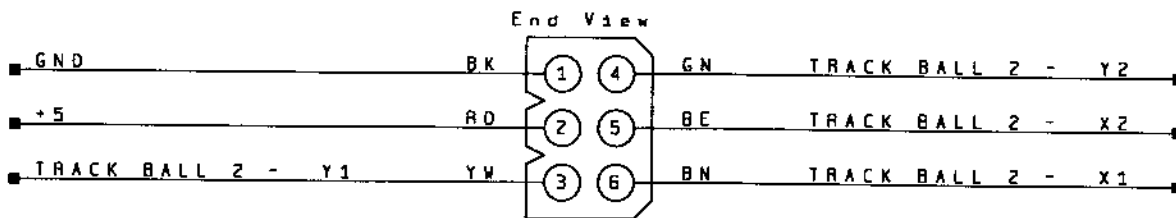

CN25\_MALE Track Ball Player 2

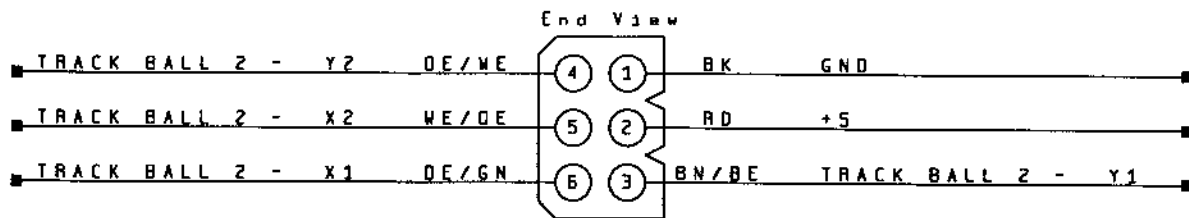

CN25\_FEMALE Track Ball Player 2

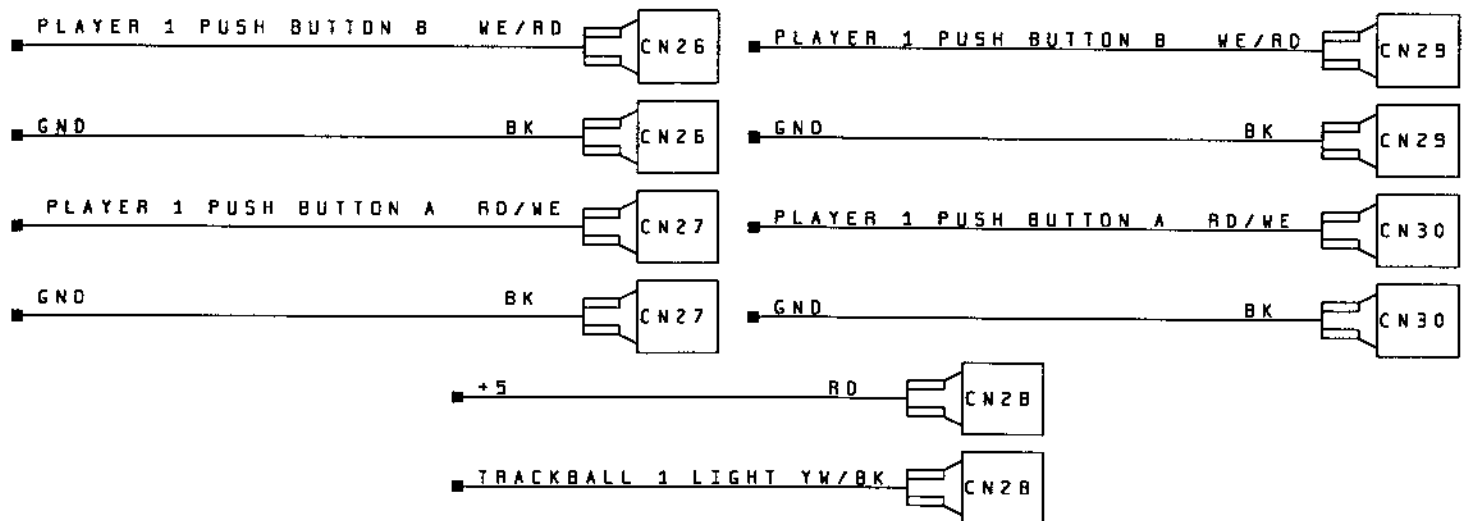

CN26-30 Player 1 Push Button Connectors & Trakball Light

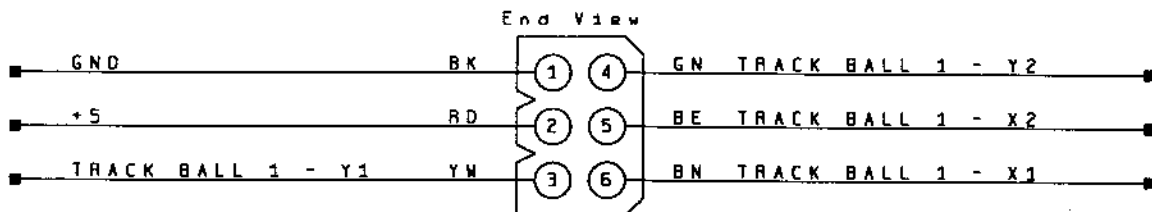

CN31\_MALE Track Ball Player 1

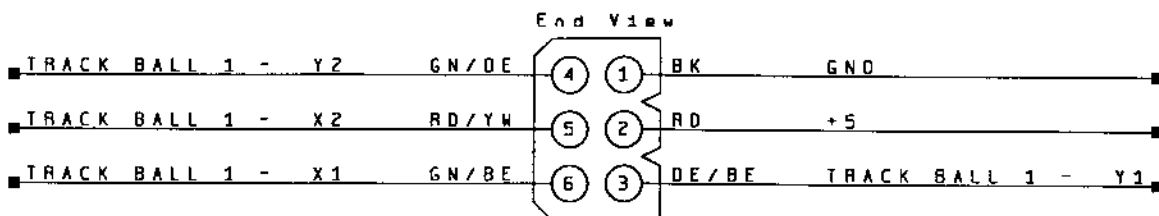

CN31\_FEMALE Track Ball Player 1

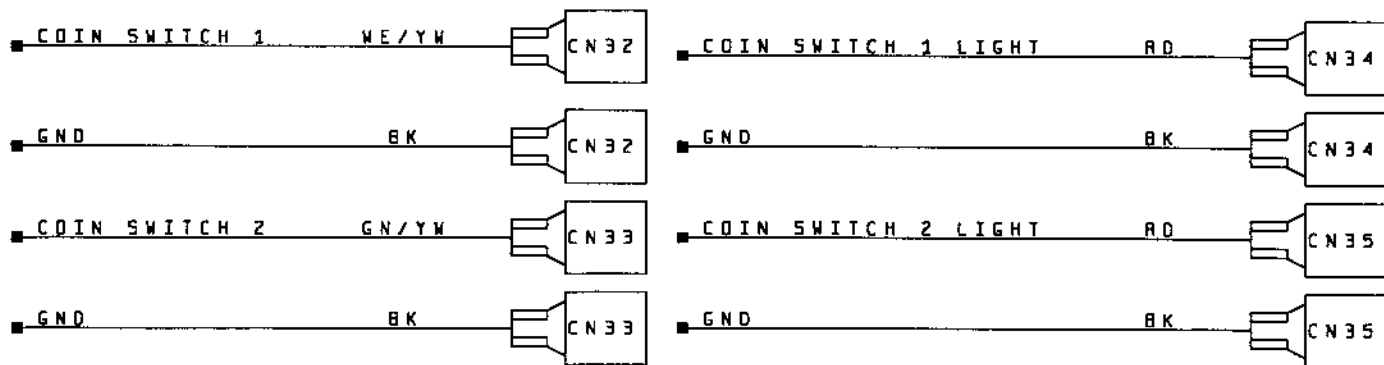

CN32-35 Coin Switches & Lights

### Ferrites

F #	Manufacture	Part #	Wires	Loops	Passes
1	Steward	28A2024-0A0	Janna (18-23, 118-124, 28, 128)	1	2
2	Steward	28A2024-0A0	Janna (8-10, 16, 108-110, 114-116)	1	2
3	Steward	28A2029-0A0	Janna (11-14, 112, 113)	1	2
4	Steward	28A2025-0A0	Janna (3, 4, 103, 104) (6, 106)	1	2
5	Steward	28A2029-0A0	DBV (All 3 Wires)	1	2
6	Steward	28A2029-0A0	Videp (all 6 Wires)	1	2
Steward	28A2024-0A0	= Dexter	0443164151		
Steward	28A2025-0A0	= Dexter	0443164251		
Steward	28A2029-0A0	= Dexter	2643167251		